



Avda. Filipinas, 46
28003 Madrid
Tfo. 91 5537207
Fax 91 5336282
E-mail grafinta@grafinta.com



GyrAnt

GyrAnt is a versatile high performance antenna (GrAnt) and combines the Inertial Measurement Unit (IMU) and the GNSS antenna. It can be mounted on flat surfaces with four screws or mounted on standard poles (5/8-11 or 1-14 inches thread).

The GyrAnt antenna provides a high quality 3D position, velocity and attitude solution because of combination of absolute accuracy of GNSS positioning and the stability of IMU gyro and accelerometer measurements. It is made of low cost inertial MEMS-based sensors and is good for autonomous navigation of vehicles passing by obstacles, like city canyons, and under bridges.

IMU consists of three gyro sensors, three accelerometers oriented in mutually orthogonal axes, all placed in the water resistant aluminum antenna housing. IMU provides measurements of angular velocity and acceleration. The system improves standalone position and velocity measurements of the GNSS receiver and provides the attitude. The JAVAD GNSS receivers firmware contains algorithm of integration of the position with IMU. For standalone case it allows to bridge GNSS gaps up to 10 - 20 seconds with precision better than 10 m.

GyrAnt can track GPS, GLONASS and GALILEO signals and can be used as standalone unit to provide the user with inertial data through the CAN or RS-422 port.

Signal	
Capability	GPS L1/L2/L5 GLONASS L1/L2/L3 GALILEO E1/E5ab BEIDOU B1/B2 WAAS L1/L5, EGNOS, MSAS, GAGAN QZSS L1/L2/L5
Frequency	1565~1610 MHz 1165~1253 MHz
Electrical	
Antenna Gain	1565~1610 MHz - 5.0 dB typ. 1165~1253 MHz - 4.0 dB typ.
Axial Ratio	3.0 dB max.
Output Impedance	50 Ohm
LNA gain	32±2 dB
Noise Figure	1565~1610 MHz - 1.7 dB typ. 1165~1253 MHz - 1.7 dB typ.
DC voltage	3.0~15.0VDC 45mA@5.0V typ.
Environmental	
Operating Temperature	-45°C ~ +85°C
Storage Temperature	-50°C ~ +85°C
Humidity	Waterproof
Mechanical	
Antenna type	Microstrip
Connector	TNC
Weight	465 g
Dimensions	140 mm x 140 mm x 62 mm
Enclosure	Radome: ABS, Base: Aluminum
Color	Green
Mounting	5/8-11 or 1-14 inches mount, or 4 holes M5
I/O	
RS422	up to 460.8 Kbps
CAN	2.0 0.5 Mbps
Electrical	
On-board power supply	+8 to +40 V DC
Power Consumption	0.5 Watt
CANH and CANL lines international termination resistor	120 Ohm, optional
IMU Performance Specifications¹ (Autonomous)	
Angular velocity	0.3 degrees/sec (rms)
Acceleration	0.025 m/sec/sec (rms)
Attitude accuracy degradation ²	< 0.02 rad per minute
Latency	~10 ms

1. Accuracy is defined for Temp=23° C

2. Degradation of attitude accuracy caused by outages of GPS measurements estimated for noiselike errors is shown in table:

Time outage, [sec]	Velocity vector degradation [m/sec]	Horizontal position degradation [m]	Vertical position degradation [m]	Roll degradation, [degree]	Pitch degradation, [degree]	Heading degradation, [degree]
5	0.4	0.9	0.2	0.1	0.1	0.2
15	1.2	8.5	1.1	0.2	0.3	0.5
60	6.5	170.0	16.0	0.5	0.6	0.8

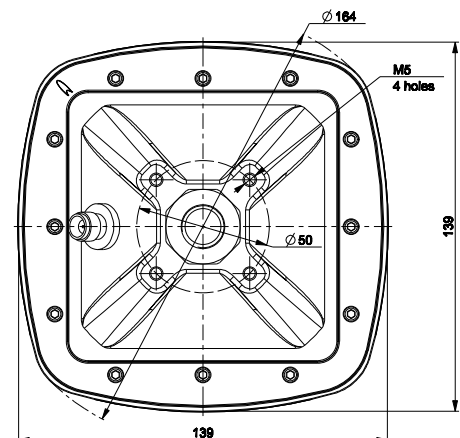
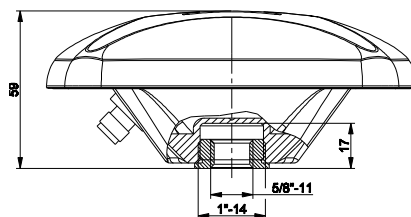

Specifications are subject to change without notice.

