



NORBIT WINGHEAD® Dual Head i77h and B41

Grafinta
Avda. Filipinas, 46
28003 Madrid
Tfo. 91 5537207
Fax 91 5336282
E-mail grafinta@grafinta.com



Superior Performance Ultra High-Resolution Dual Head Bathymetric System.

NORBIT introduces the first cylindrical ultra-high resolution curved array Dual Head bathymetric system, designed for rapid anywhere anytime mobilisation featuring the highest standard industry leading integrated GNSS/INS positioning system.

NORBIT WINGHEAD sonars are based on a state of the art analogue and digital platform featuring powerful signal processing capabilities, offering roll stabilized bathymetry and several imagery and backscatter outputs ensuring the highest quality survey data performance. With broad R&D expertise, NORBIT has developed - from the ground-up - exciting new technology that allows existing and new applications to benefit from the advantages offered by a compact wideband curved-array multibeam sonar.

The NORBIT WINGHEAD Dual Head configuration i77h and B41 is a compact ultra-high resolution curved array broadband multibeam sonar offering tight integration with GNSS/INS (Applanix OceanMaster) that is designed for use in the most demanding rough sea conditions and in operational environments with poor GNSS coverage, such as around offshore platforms. Characterised further by a small form factor; low power draw and tight integration, WINGHEAD Dual Head uniquely facilities both wide coverage and increased sounding density from a single user interface.

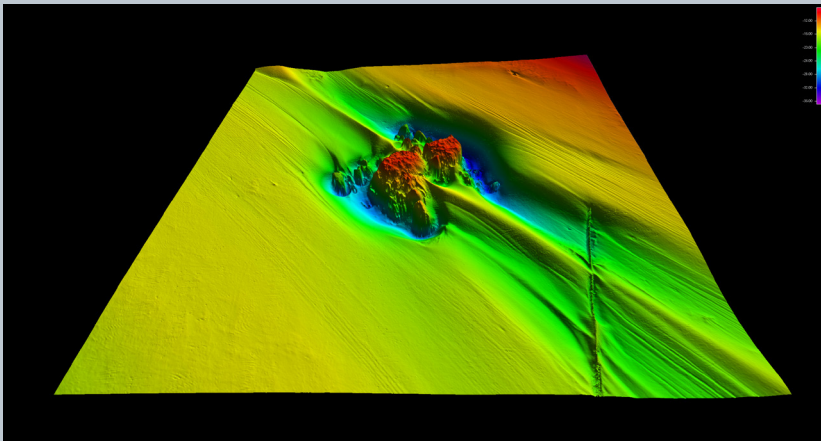



WINGHEAD Dual Head

NORBIT
- explore more -

Features	Applications	Options
<ul style="list-style-type: none"> ✓ Multibeam Sonar with Integrated Inertial Navigation System & Integrated NTRIP Client ✓ 80kHz Bandwidth ✓ Roll-stabilisation ✓ Backscatter outputs (Intensity, Sidescan, Snippets Sidescan, Snippets, Water Column) ✓ Multidetect ✓ Pipeline Mode ✓ Simple Ethernet Interface ✓ Integrated Sound Velocity Probe ✓ 2048 Dynamically Focused Beams ✓ FM & CW Processing ✓ Exceeds IHO <i>Special Order</i>, CHS <i>Exclusive Order</i> & USACE <i>New Work</i> 	<ul style="list-style-type: none"> ✓ Shallow Water High Density Charting ✓ Pipeline & Cable Inspection Surveys ✓ Harbour; Quay wall, Bridge and Structure Engineering Inspection Surveys ✓ Offshore Inspection, Repair and Maintenance (IRM) Operations ✓ Pond, River, Lake and Estuary Surveys ✓ USV & UUV ✓ Coastal Surveys ✓ Renewable Energy 	<ul style="list-style-type: none"> ✓ Sound Velocity Profiler ✓ Turnkey Survey Solutions ✓ Permanent Hull Mount, Non-corrosive Titanium Housing ✓ 37° Bracket ✓ Extended Depth Range ✓ Flexible Surface/ROV Configuration ✓ Pole Mount ✓ Supports NORBIT iLiDAR ✓ Detached INS Version ✓ Can be Delivered with Software Packages e.g. HYPACK, Qinsy, EIVA, CARIS and Others

TECHNICAL SPECIFICATION

SWATH COVERAGE	5-230° FLEXIBLE SECTOR
RANGE RESOLUTION	<10mm ACOUSTIC w. 80kHz BANDWIDTH
NUMBER OF BEAMS	512, 1024, 2048 EA & ED
OPERATING FREQUENCY	NOMINAL FREQUENCY 400kHz (FREQUENCY AGILITY 200-700kHz)
DEPTH RANGE	0.2m to >400m*
PING RATE	UP TO 60Hz, ADAPTIVE
RESOLUTION (ACROSS X ALONG)	STANDARD: 0.5° X 0.9° @400kHz, 0.3° x 0.5° @700kHz
POSITION	HOR: ±(8mm +1ppm x DISTANCE FROM RTK STATION) VER: ±(15mm +1ppm x DISTANCE FROM RTK STATION) (ASSUMES 1m GNSS SEPARATION)
HEADING ACCURACY	0.02° (RTK) WITH 2m ANTENNA SEPARATION
PITCH/ROLL ACCURACY	0.01° INDEPENDENT OF ANTENNA SEPARATION
HEAVE ACCURACY	2 cm OR 2% (TRUEHEAVE™), 5 cm OR 5% (REAL TIME)
INTERFACE	ETHERNET
POWER CONSUMPTION	<165W (10-28VDC, 110-240VAC) TOTAL
DIMENSIONS	DIMENSIONS WITH BRACKET H: 894.9mm/35.23", L: 300.6mm/11.834", W: 172.0mm/6.771"
WEIGHT	TOTAL WEIGHT OF BOTH SONARS AND BRACKET 19.9kg IN AIR AND 9.4kg IN WATER.
CABLE LENGTH	STD 8m, OPTIONAL: 2m, 25m, 50m
OPERATING TEMP.	-4°C to +40°C (TOPSIDE -20°C to +55°C)
STORAGE TEMP.	-20°C to +60°C
ENVIRONMENTAL	TOPSIDE: IP67: DUST TIGHT, PROTECTED AGAINST THE EFFECT OF IMMERSION UP TO 1m WET-END (SONAR): 100m

* Typical Swath ±20° @ 30ppm, 10°C

OUTLINE DRAWING

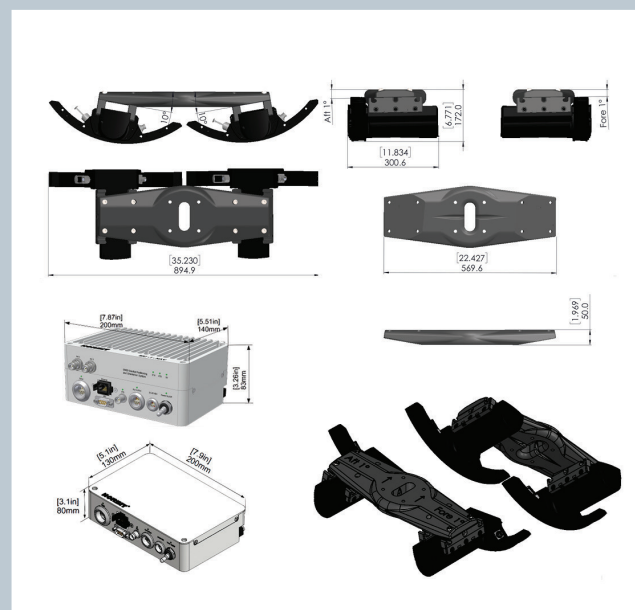

Sonar including bracket (bracket shown in grey)